



## Design and Fabrication of Mechanical Pedal Powered Hacksaw for Engineering Workshop Practice

Amaechi, O. Joseph (PhD)<sup>1</sup>, Dick, Daniel Chubueze<sup>2</sup>, Anga, Boma Martins<sup>2</sup> and Thomas, Chinujinim Godstime<sup>3\*</sup>

<sup>1</sup>Department of Industrial Technology Education, Ignatius Ajuru University of Education, Rumuolumeni, Port Harcourt, Rivers State. Email: [amaechijoseph@yahoo.com](mailto:amaechijoseph@yahoo.com) & [amaechijoseph45@gmail.com](mailto:amaechijoseph45@gmail.com) Phone: 08034831161

<sup>2</sup>Department of Technology Education, Rivers State University, Nkporlu Oroworukwo, Port Harcourt, Rivers State

<sup>3</sup>Department of Industrial Technical Education, Federal College of Education (Technical) Omoku, Rivers State. Email: [thomaschinujinim@fctomoku.edu.ng](mailto:thomaschinujinim@fctomoku.edu.ng) & [chinujinimthomas@gmail.com](mailto:chinujinimthomas@gmail.com) Phone: 08066811166

---

### ABSTRACT

This project work deals with the design and fabrication of a mechanical pedal powered hacksaw cutting machine. The aim of this work is to develop a modernized and less stressful operation for cutting wood, metals and plastic materials. It is very useful for cutting PVC materials (pipes) and can be used widely in lather and in furniture making industries. This work can also serve as an exercising machine for fitness while cutting; it uses the principle of a slider crank mechanism which converts the rotary motion of the flywheel to the reciprocating motion of the hacksaw during pedaling. The machine was tested and found to be very efficient with an ideal mechanical advantage.

**Key words:** Slider Crack Mechanism, Fabrication, Pedal power

---

### INTRODUCTION

Throughout history, human energy has generally been applied through the use of the arms, hands, and back. With minor exceptions, it was only with the invention of the sliding- seat, rowing shell, and particularly the bicycle that legs also began to be considered as a “normal” means of developing power from human muscles.

Pedal power is the transfer of energy from a human source through the use of a foot pedal and crank system. Mukund *et al* [1] this is a technology commonly used for transportation and has been used to propel or transmit motion on bicycles for over hundred years ago. Most pedal power is used to power agricultural and hand tools and even to generate electricity. Some other applications include pedal power grinders and pedal power water wells etc.

Mechanical pedal power operated hacksaw machine utilizes the energy generated by foot pedaling in metal cutting operations in which no electrical power is needed. According Sivasubramanian *et al* [2] an individual can generate four times more power (1/4 HP) by pedaling than by hand- cranking. At the rate of ¼ HP, continuous pedaling can be served for only short periods, approximately 10 minutes. However, pedaling at half this power (1/8 HP) can be sustained for close to 60 minutes but power capability can depend upon age.

Ashok Kumar *et al* [3] a pedal powered hacksaw setup has a simple mechanism operated with chain and sprocket gear arrangement. Such that during pedaling the wheel rotary motion is converted into the “To and Fro” motion of the cutting tool (Hacksaw). Sivasubramanian *et al* [2] a saw is a tool that uses a hard blade or wire with an abrasive edge to cut through softer materials. The cutting edge of a saw is either a serrated blade or an abrasive. A saw may be worked by hand, or powered by steam, water, electric or other power. A pedal operated hacksaw could be manually fabricated pedal operated hacksaw which is mainly used for cutting metals, wood and plastics. The machine is designed to yield a high mechanical advantage to reduce the effort needed to do that work.

- i. Create job opportunities during the manufacturing and installation process.
- ii. Reduce the peak load demand and grid fluctuation problems as it saves electricity which would have been used by an electrical power hacksaw.

- iii. Increase the researcher's practical skills.
- iv. Saves time when compared to the hand hacksaw.
- v. Saves cost of purchase and maintenance when compared to electrical power hacksaw.

In today's modern world, where new technologies are introduced every day, electrical energy, fossil fuel particularly petroleum fuel is the major contributor to electrical generation. The quick depleting reserve of petroleum and decreasing air quality raises question about the future. Mechanical energy can be used as an alternative energy to reduce the demand of electrical power, and it is more favorable in establishing an environmentally friendly working condition.

The fabrication of a mechanically manual pedal hacksaw is geared towards addressing or solving some technological and economical challenges faced in a mechanical workshop without the application of electricity. The mechanically pedal hacksaw machine runs on human power, works on the principle of the conversion of rotational motion to oscillatory motion [1]. This is a project which saves electricity need and can be easily used in day to day human construction activities in the workshop.

### Conceptual Design Framework

Mechanical pedal powered hacksaw is a manually operated cutting machine which is used for cutting metals, wood and plastics. The machine is designed to yield a high mechanical advantage to reduce the effort needed to do that work. It consists of a chassis frame (stand set up), a pedal arrangement, a vice, a seat, a hacksaw blade, a connecting rod, a flywheel, three roller ball bearings, a metal slap etc.

This machine basically works on the principle of Slider Crank Mechanism which is the heart of this machine. Slider Crank is a mechanism used to convert the rotary motion of the crank into the reciprocating motion of hacksaw. The rotary motion through pedal is transmitted to the crank connecting hacksaw frame which is guided over a circular rod [4].

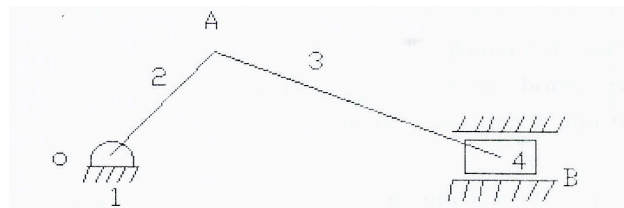

**Fig. 1** Single slider crank mechanism

A slider crank mechanism converts circular motion of the crank into linear motion of the slider. It converts rotary motion into a reciprocating motion to cut the materials [5]. In figure 1 above, link 1 is fixed and link 2 which is a crank is rotating about fixed link 1 and converts this rotary motion into the reciprocating motion of slider (corresponds to the link 4) by means of connecting rod which corresponds to the link 3. This is the inversion of single slider crank which is obtained by fixing link 1.

### Working Drawings and Assembly

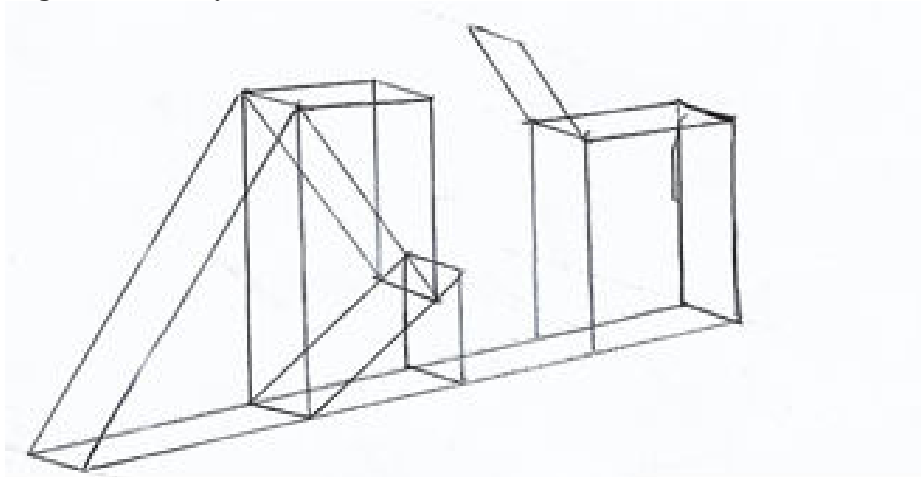

**Fig. 2** Base frame

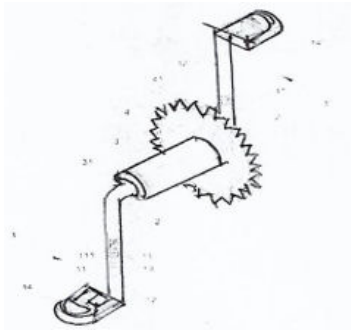

Fig. 3 Crank and pedal mechanism

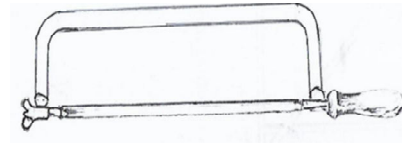

Fig. 4 Hacksaw

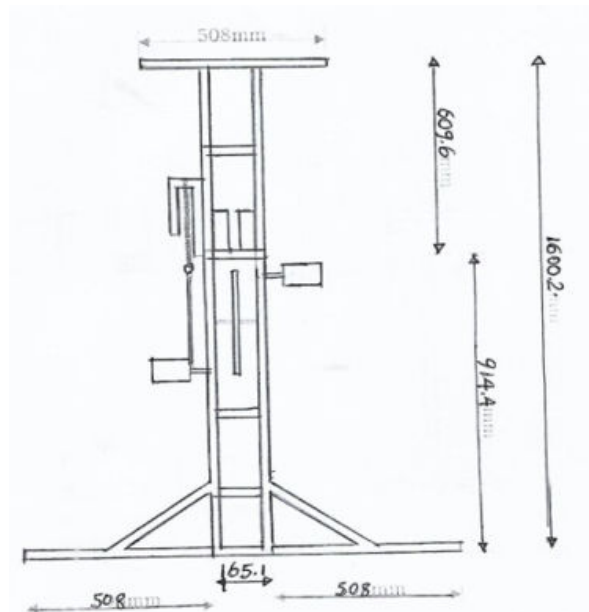

Fig. 5 Front View of the mechanical pedal powered hacksaw

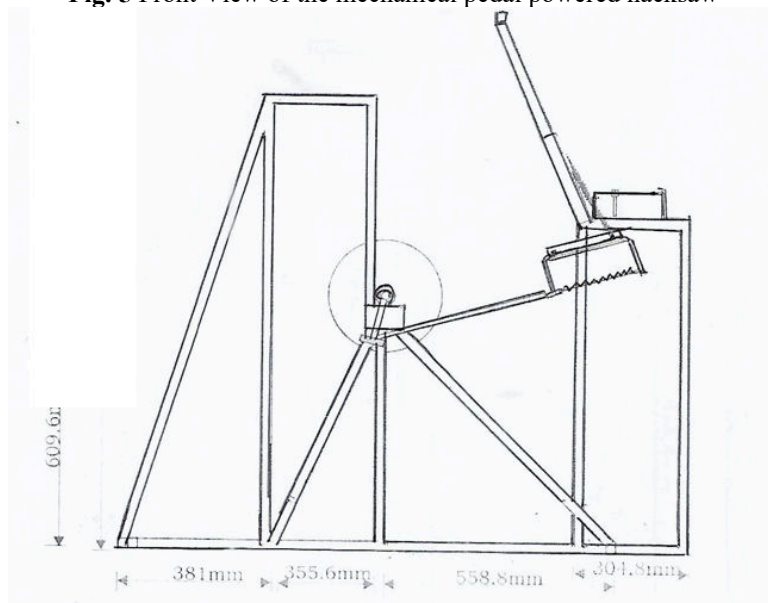

Fig. 6 Side View of the mechanical pedal powered hacksaw

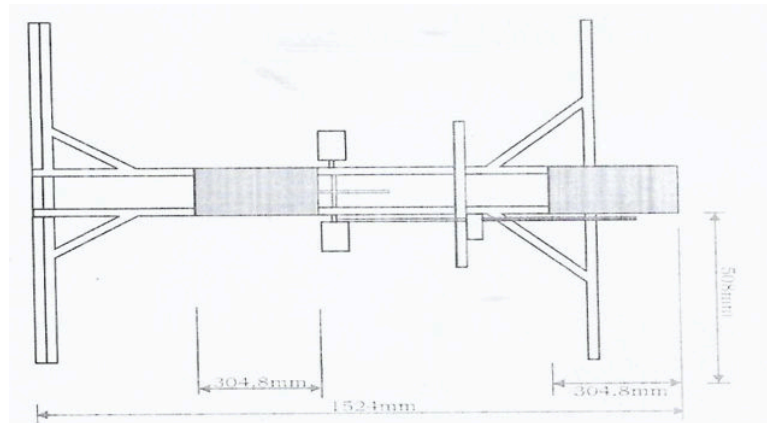

Fig. 7 Plan of the mechanical pedal powered hacksaw

### MATERIALS AND METHODS

- A 25.4 mm by 25.4 mm mild steel square pipe
- 609.6 mm mild steel base plate of 4 mm thickness

Table -1 Description of Materials used

S/N	Quantity	Description	Length in mm
1.	2	Mild steel square pipe chamfered at angle 45 <sup>0</sup> at one end	1524
2.	2	Mild steel square pipe	1219.2
3.	2	Mild steel square pipe	914.4
4.	3	Mild steel square pipe chamfered at angle 45 <sup>0</sup> at both end	609.6
5.	2	Mild steel square pipe chamfered end to end at angle 45 <sup>0</sup>	152.4
6.	8	Mild steel square pipe	114.3
7.	2	Mild steel square pipe	889
8.	2	Mild steel square pipe chamfered	1219.2
9.	2	Mild steel square pipe chamfered	697.9
10.	2	Mild steel flat bar	482.6
11.	1	Cylindrical mild steel slab of 25.4mm diameter	139.7
12.	2	Mild steel base plate	304.8 x 304.8
13.	6	Mild steel square pipe	508

### Machines, equipment's and tools used for the construction

- The hacksaw
- The lathe machine
- The arc welding machine
- The grinder
- The hammer
- The pliers
- The spanners
- The Power drill
- The Anvil
- The hand shear
- The Bench Vice
- A work Bench

### **Fabrication Process**

According to Khaja and John [6] metal fabrication is the building of metal structures by cutting, bending, and assembling processes: Cutting is done by sawing, shearing, or chiselling (all with manual and powered variants); torching with hand-held torches (such as oxy-fuel torches or plasma torches); and via numerical control (CNC) cutters (using a laser, mill bits, torch, or water jet).

Bending is done by hammering (manual or powered) or via press brakes and similar tools. Modern metal fabricators utilize press brakes to either coin or air-bend metal sheet into form. CNC-controlled back gauges utilize hard stops to position cut parts in order to place bend lines in the correct position. Off-line programming software now makes programming the CNC-controlled press brakes seamless and very efficient.

Assembling (joining of the pieces) is done by welding, binding with adhesives, riveting, threaded fasteners, or even yet more bending in the form of a crimped seam. Structural steel and sheet metal are the usual starting materials for fabrication, along with the welding wire, flux, and fasteners that will join the cut pieces. As with other manufacturing processes, both human labor and automation are commonly used. The product resulting from fabrication may be called a fabrication. Shops that specialize in this type of metal work are called fabrication shops. The end products of other common types of metalworking, such as machining, metal stamping, forging, and casting, may be similar in shape and function, but those processes are not classified as fabrication.

Other production operations involved in the fabrication process are: marking-out operation, drilling operation, welding operation, finishing section, and the assembly process.

### **Marking Operation**

With the help of a measuring tape, the steel rule, the try square, center punch, steel chalk and a scribe, the required lengths necessary for the construction of a pedal operated hacksaw was marked out on the square pipe.

### **Drilling Operation**

Drilling is the process of using a drill bit in a drilling machine to produce cylindrical holes on materials. The required holes were drilled using the correct drill bit sizes. All safety precaution where strictly followed.

### **Welding Operation**

Welding is a fabrication or sculptural process that joins materials permanently, usually metals or thermoplastics, by causing coalescence. The various joints required in the pedal powered hacksaw machine were permanently joined using an arc welding process.

### **Surface Finishing**

In order to add more beauty to the work, we applied the following surface finishing.

- i. Sand papered it to have a smooth surface.
- ii. We also filled it properly with filler
- iii. Painting was done in order to enhance good look of the project and to avoid corrosion parts.

### **Fabrication Procedure**

#### **Construction of hacksaw connection rod:**

The length of the hacksaw connecting rod was determined by using a trial by a try square until the right and desired length was achieved.

A 25.4mm by 25.4mm mild steel square rod of 228.6mm length was used for the connecting rod.

**Metal Slab:** Metal slabs were fitted on the hacksaw blade to ensure pressure on the object to be cut and linear movement of the blade.

A cylindrical mild steel rod of length 140mm and Diameter 25.4mm was welded on the hacksaw frame for this purpose.

**The Hacksaw:** The Hacksaw is a cutting mechanism which is provided by removable blades which feature sharp teeth along their outer edge. In most cases, a hacksaw consists of a metal frame, blade, adjustable screw, handle etc.

Most Hacksaws are made from Low Tungsten Steel or Carbon steel; however, the more expensive blades are made horn High Speed Steel.

Hacksaw blades are normally quite brittle, so care needs to be taken to prevent brittle fracture of the blade.

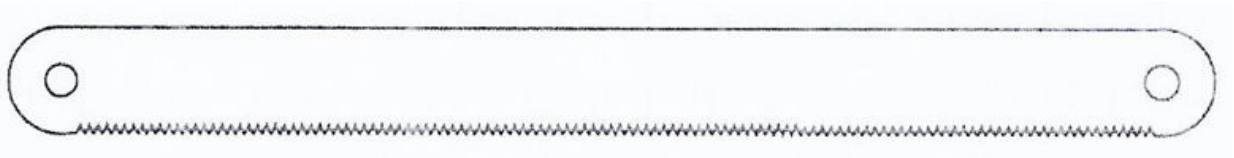

**Fig. 8** A standard 1 foot (304.8mm) hacksaw blade

### Parts of a Hacksaw

**The Frame:** There are two types of Hacksaw Frame, a fixed and an adjustable. The fixed frame can only take one length of Blade, but is more rigid than the adjustable type, which can take Blades of different lengths.

**The Handle:** There are three types of 1-lacksaw Handle used:

- (a) File Handle or Straight Handle
- (b) Pistol Grip Handle
- (c) Wood saw Handle

The most commonly used handles are the File Handle and the Pistol Grip Handle

**The Blade:** There are also two main types of Blades, but in the case of both, the teeth on the Blade are facing away from the Handle towards the front of the hacksaw.

The first type of Blade is the All Hard Blade which has been hardened throughout. As a result, there is more efficient cutting but the blade tends to break more easily.

The second type of Blade is the Flexible Blade which has hardened teeth but the remainder of the body remains soft. The Blade, as a result, is more flexible and breaks less easily. It is an ideal blade for the school workshop as it will take rougher treatment.

When fitting a new blade to a hacksaw, point the teeth forward, (away from the handle). Tighten the wing nut to remove the slack and then as a general rule tighten three turns, it is important to have the correct tension on the blade, if it is too loose then the blade will buckle and not cut straight, and if it is too tight. Damage to the blade ends or the frame may result.

### Selecting a Hacksaw blade

Proper blade selection is important. Use the three-tooth rule at least three teeth must be in contact with the work. Large sections and soft materials require a coarse-tooth blade. Small or thin work and hard materials require a fine-tooth blade. For best cutting action, apply heavy feed pressure on hard materials and large work. Use light feed pressure on soft materials and work with small cross sections. Blades are made in two principal types: flexible-back and all-hard blade. The choice depends upon use.

- i. **Flexible-back blades:** should be used where safety requirements demand a shatterproof blade. These blades should also be used for cutting odd-shaped work if there is a possibility of the work coming loose in the vise.
- ii) **All-hard blade:** For a majority of cutting jobs, the all-hard blade is best for straight, accurate cutting under a variety of conditions.

When starting a cut with an all-hard blade, be sure the blade does not drop on the work when cutting starts. If it falls, the blade could shatter and flying pieces' cause injuries.

Blades are also made from tungsten and molybdenum steels, and with tungsten carbide teeth on steel alloy backs. The following rule-of-thumb can be followed for selecting the correct blade: Use a 4-tooth blade for cutting large sections or readily machined metals. Use a 6-tooth blade for cutting harder alloys and miscellaneous cutting. Use 10- and 14-tooth blades primarily on light duty machines where work is limited to small sections requiring moderate or light feed pressure.

### Mounting of the Hacksaw blade:

The blade must be mounted to cut off the back stroke. The blade must also lie perfectly flat against the mounting plates. If long life and accurate cuts are to be achieved, the blade must be properly tensioned. Many techniques have been developed for properly mounting and tensioning blades. Use a torque wrench and consult the manufacturers' literature. If the information (proper torque for a given blade on a given machine) is not available, the following methods can be used: Tighten the blade until a low musical ring is heard when the blade is tapped lightly. A high-pitched tone indicates that the blade is too tight. A dull thud means the blade is too loose. The shape of the blade pin hole can serve as an indicator of whether the blade is tensioned properly. When proper tension is achieved, the pin holes will become slightly elongated. The blade will become more firmly seated after the first few cuts and will stretch slightly. The blade will require re-tensioning (retightening) before further cutting can be done.

### Construction of Vice

A clamp, with 360 degree rotation, was fixed to hold the metal pieces while cutting, and to allow them to be cut in any shape and angle.

A simple vice was constructed using 2 Mild steel flat bar of:

Length: 482.6mm  
Width: 40mm  
Thickness: 50mm

### Dimension of Vice:

Base: 50.8mm  
Height: 101.6mm  
Length: 152.4mm

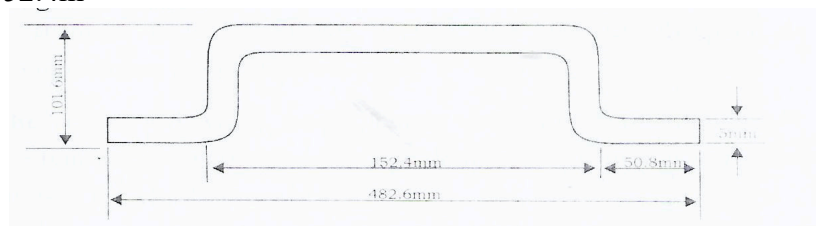

Fig. 9 The vice

### Construction of Crank

The bicycle drive train reciprocating motion legs chain belt, which in turn drives the rear wheel. It have pedal, crank to the bicycle frame at the bottom bracket, and also at the rear sprocket, cassette freewheel crank set is the component that converts the human pedal effort into rotational motion used to drive chain wheels attached to the arms. It is connected to the rider by the or via the chain.

But in this crank set the two cranks, one on each side is mounted in same direction as compared to the conventional crank of mounting 180° apart connect the bottom bracket axle to the pedals.



**Fig. 10** The Crank

### Construction of Pedal

The pedal was constructed or modified to achieve the require cutting length or effective cutting. A standard hacksaw is 1 foot long which is about 12inches or 304.8mm, and the standard pedaling diameter of a standard bicycle is about 370mm, therefore the pedaling diameter of the Driver or pedals has to be reduced to accommodate the cutting axis of a standard hacksaw blade of 304.8mm.

Original length of pedal: 185mm

Original Pedaling Diameter: 370mm

A length of 58mm was cut off from both pedals of the bicycle w make the new modified pedal, giving us a thus;

Modified length of pedal: 127mm

Modified Pedaling Diameter: 254mm

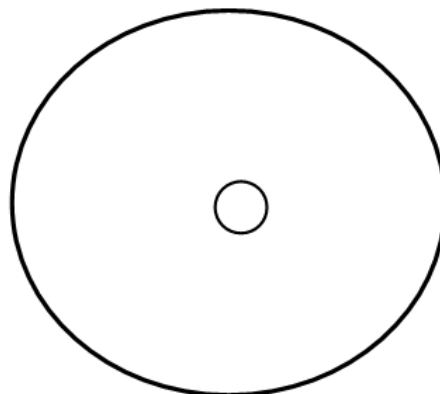

**Fig. 11** The Pedal

### Construction of Flywheel

A circular mild steel base plate of 3 100mm diameter and 5mm thickness was used as the flywheel. A through hole of 20mm was drilled on the flywheel to accommodate the center rod.

The center rod which has a length of 228mm and diameter of 1.84cm as step turned to obtain a diameter of 15mm at both end up to a length of 50mm at both end.



**Fig. 12** Flywheel



**Construction of Guild:** Guild was used to control the hacksaw blade which is used to cut the metal in order to reduce play. Using a 25.4mm by 38.1mm mild steel square pipe.

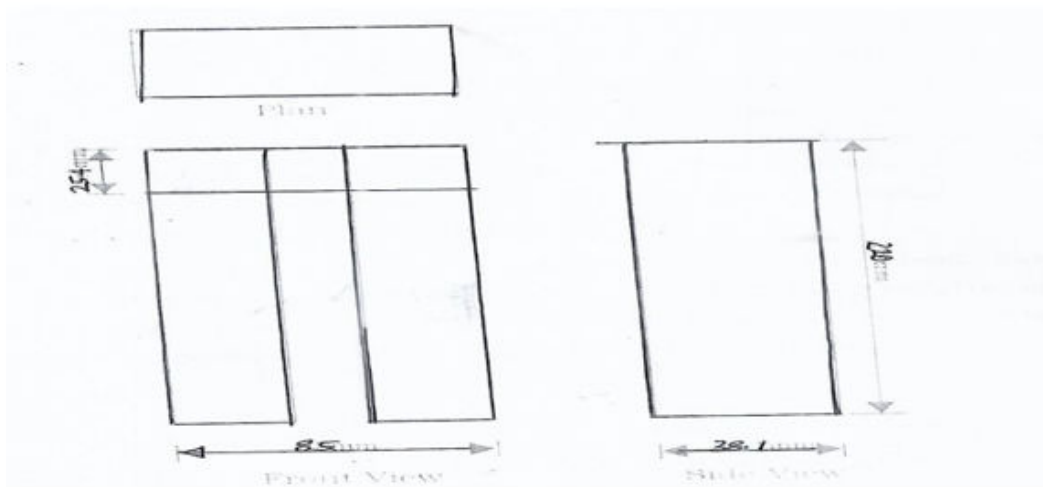

**Fig. 13** Orthographic projection of the guild in 3<sup>rd</sup> angle projection

#### Assembly of the Components

This is an assembly which comprises all the parts, that is, putting together the component that makes up the pedal hacksaw. The fabrication diagram comprises all the steps taken by LIS as shown below.

The pedal operated hacksaw was tested after assembling, by tightening a square pipe on the vice, and cut with the help of the pedal saw.



**Fig. 14** Mechanical Pedal Powered Hacksaw

#### Quality control and finishing section

The most important factor we considered in the quality control was that we ensured that all the components were fixed together correctly, during the assembly process.

## Conclusion

The pedal powered hacksaw machine was constructed with mainly locally sourced materials that could conserve energy requirement and save cost. It is successful research and the fabrication, construction was achieved using available raw materials and techniques. Metals pipes, plastics and pieces of wood were cut successfully and the overall performance was confirmed to be efficient compared to already existing ones. The Following advantages were noted

1. The cost of production and maintenance is relatively cheap,
2. It is more convenient and easier to operate,
3. It is eco-friendlier.
4. Electrical power is not required. Hence, the machine could be used for physical exercise and also needed by industries given its performance, affordability and simplicity.

This simple cutting machine can be used to solve day today household metal cutting needs and it can be also used in for small entrepreneurial workshops and in industrial applications during power shut down.

## Recommendations

Following the successful completion of this project work, the following recommendations are state below.

1. Technological research centers should be built, by the government and researchers should be well funded for projects like this.
2. Farm implements or small machines can be driven at speeds up to 800RPM using this pedal operated machine. High speeds (500 — 800RMP) can be achieved by using chain drive or v- belt that must be properly tensioned in order to deliver adequate torque without slipping.
3. Speed less than 500RPM and especially for very high torque applications such as grinding, roller - chain drivers are recommended. Speeds in excess of 800RPM can he achieved by using larger diameter pulleys.
4. The seat should be adjusted to permit full extension of the leg during pedaling.

## REFERENCES

- [1]. Mukund, S. G.; Mahesh S. G.; Suraj, D. S. and Prashant, T. S. (2017). Design and fabrication of two way padel operated hacksaw machine. *International Journal of Scientific Development and Research (IJS DR)*, 2 (4), 281 – 283.
- [2]. Sivasubramanian, S.; Manikandan, M.; Sabariraj, V. and Vishal, S. (2018). Design and fabrication of pedal operated hack saw. *International Journal of Engineering Research & Technology (IJERT)*, ETEDM - 2018 Conference Proceedings, 6 (4), 1 - 4.
- [3]. Ashok Kumar, K.; Ramakrishna, G.; Malleswararao, B.N.; and Lakshmi Narayana, V. (2018). Design and fabrication of pedal power hacksaw. *International Journal of Research and Analytical Reviews*, 5 (2), 1255 - 1262.
- [4]. Sahu, S. S.; Ashish, K. S.; Sanjeev, K. P. and Sibabrata, M. (2016). Fabrication of two-way pedal powered hacksaw machine. *International Journal of Innovative Science, Engineering & Technology*, 3 (3), 683 – 687.
- [5]. Pratik, D.; Chaudhary, P.; Solanki, C.; Vaghela, J. and Rahari, M. (2015). *Pedal power hacksaw*. The B. S. Patel Polytechnic Press.
- [6]. Khaja, M. G. H. and John, T. B. (2016). Fabrication of pedal powered hacksaw machine. *International Journal of Scientific Development and Research (IJS DR)* 1 (8), 260 – 268.