



Design and Fabrication of Solar based Electric Bicycle

¹Priyanka Gaurkhede, ²Shital Yende, ³Rahul Dekate, ⁴Kiran Narnaware

Department of Electrical Engg, Suryodaya college of Engg, Nagpur

¹priyankagaurkhede123@gmail.com, ²shitalyende21@gmail.com, ³rahuldekate17@gmail.com,

⁴kirannarnaware29@gmail.com

ABSTRACT

The key idea of this paper is to give the exact view by checking the several bases of energy accessible to mankind. In today's reorganized world itinerant is very vital for human beings in order to protract in this world. And to do so his wandering should be done in tiniest promising way and in minute. This paper minutiae around the Electric bicycle which goes on the battery thereby as long as voltage to the motor. This paper conciliations with plan and construction of Electric bicycle which styles use of Electric energy as the main source and solar energy by assigning solar panels. It also acmes on the design aspects of the bicycle. There is a facility for arranging the battery by refusing it from the focal system. The electrical power produced which is used to run the bicyclea can provide better fuel economy compared to conservative vehicle, improved show and also causes less smog.

Key words: Travelling, Electric Bicycle, Electric Energy, Solar Panels, Fuel Economy

INTRODUCTION

A solar based bike is a bike which runs utilizing the electrical vitality of battery to run the center point engine which eventually runs the bike. Sunlight based vitality is utilized to charge the battery. At least two Photovoltaic cells might be utilized to outfit sun powered vitality to create voltage to charge the battery. Battery gives the necessary voltage to the center point engine mounted on the front wheel to run the bike. Sunlight based bike are not sold for the most part in our regular daily existence however there assembling can be expanded to forestall ecological contamination. These are principally utilized as a functional tasks and are likewise some of the time supported by government offices. Using solar based vitality to charge the battery and joining this idea with the idea of power age accelerating is another idea and there have been less research in such manner. Solar oriented bike utilize photovoltaic cells that convert solar based vitality into expected voltage to charge the battery. There are two kinds of solar based boards that are commonly utilized that is polycrystalline boards and microcrystalline solar based boards. There are various kinds of batteries utilized in electric vehicles like lead corrosive batteries, lithium particle batteries, Nickel cadmium batteries, and so on. Various batteries they have their various points of interest for various applications. Undoubtedly lead corrosive and lithium particle batteries are most generally utilized. Lead corrosive batteries have lower cost, higher current conveying limit yet have littler life and are heavier. While lithium particle batteries have lower weight yet has greater expense and there are odds of explosion. The exhausting store of petroleum product made the architects and researcher to search for the sustainable power sources. On the off chance that we use solar based force for neighborhood movement, a lot of cash can be spare and we can likewise guarantee contamination free condition and contribute towards country economy. Bike being the least expensive and most advantageous method of transportation however presents issue in climbing slants. Engine cycles are not moderate for the

vast majority of the ordinary citizens with expanding petroleum cost. Subsequently a bike which can be pedal just as run on a solar oriented force battery appears to be appropriate choice to tackle the issue. Sun oriented bike otherwise called solar based E-bicycle is an electric bike. An electric engine which is driven by the utilization of intensity from the battery which is being charge utilizing solar based vitality by sun powered board. Photovoltaic (PV) cells interface contains in sun powered boards convert the sun vitality legitimately into electric vitality are utilized.

LITERATURE VIEW

Georgia Apostolou, Angèle Reinders and Karst Geur; They have considered the term electrical bicycle or 'e-bicycle' alludes to every one of the two-wheeled electric vehicles (EVs), all the more explicitly to bikes, with various degrees of help to the client. A little electric engine and a battery- powered battery are utilized to help the force that is given by the rider. The battery can give vitality to high speeding up under hard biking conditions, for example, climbing slants and beating wind opposition, in this way broadening the scope of the excursion.

Mayur Parmar, Rushi Trivedi, Santosh Nair, Vikit Vora; The sun powered board is a photovoltaic converter which works in brilliant daylight and in diffused daylight. The DC voltage promoter saves the voltage ideal for the battery to get charged even while the voltage falls underneath limit in diffused daylight. The blockage diode utilized in the charger keeps the converse progression of current from the battery to sunlight based board speed controlling signs dependent on the revolution of the actuator.

METHODOLOGY OF SOLAR BICYCLE

- A) BATTERY: 12 volt battery for starting of generating energy or a electric source. It is also use to give a power supply to the motor so it will run bicycle. It gives a 12 volt -7.5 Ah power. It is a lead acid battery and its weight about 2kg. This type of battery can be recycle.
- B) SOLAR PANEL: We are using a polycrystalline type of solar panel. Solar panel is of 25 watt & 12V & it weight is about 1kg. High modules conversion efficiency 25W solar panel and its efficiency is 80%. It requires use space so that if will produce energy faster as compare to other.
- C) ACCELERATOR: It is use to control the speed of bicycle. It produces beams of a charged particle that can be used for a variety of purpose. Basically, it will help to control the speed in traffic.
- D) MOTOR: It will convert the electric power into mechanical or rotational movement. The motor we use is of 250W and 25V. Its rpm is 300. The weight of the motor is about is 2.5 to 3kg.
- E) MOTOR SPEED CONTROLLER: It will initially start the power supply to the bicycle. It is of 25V (rated voltage DC) & 250W (rated power), Throttle is of 1-4. This is a brushed controller type and its weight is 200g.
- F) DYNAMO METER: It is of 12V, 5 amp. It will convert rotational motion into electric current. When the rotor cut through line of magnetic flux it generates electricity.
- G) CYCLE: It is the base component of the project. All the other component are mounted on the cycle



Fig. 1

WORKING

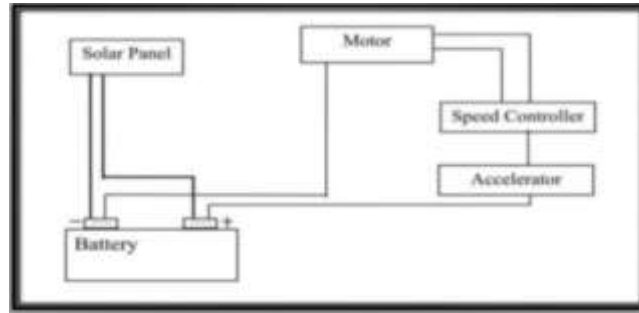

Fig. 2

The sun powered e-bike is to utilize vitality that is put away in a battery during and in the wake of charging it from a solar based board. The charged batteries are utilized to drive the engine which serves here as a motor and move vehicle.

The working standard of solar oriented e-bicycle is that it is driven by the utilization vitality put away in the batteries. Sun powered board changes over the solar based vitality striking on the board by the utilization of photovoltaic cells in the board and it is put away in the batteries. Batteries can likewise be charge by power as an optional source. The centre point engine fitted in the back hub plunges the bike which is controlled by the batteries. The solar oriented board produces power while the bike is inactive also it is moving. The whole framework works productively with the utilization of engine controller which controls the force stream from the batteries. The driver can pick the charging choices just as the riding choice whether it is completely depending on batteries or the regular technique.

DESIGN CALCULATIONS

- 1) Cd = Coefficient of air drag = 1
- 2) A = Total area of the rider, if seen from front = 0.5 m²
- 3) ρ = Air density
- 4) Vw = wind speed = 7km/hr (avg) = 1.94 mps
- 5) Vg = cycle speed = 30km/hr (max) = 6.94 mps
- 6) Cr = coefficient of rolling resistance
- 7) Mtot = Total mass of rider and bicycle
- 8) G = Road grade = sin((Δh/Δl)/100); Δh=10m, Δl=50m
- 9) Diameter of wheel = 60cm
- 10) Weight of cycle = 22kg
- 11) Weight of rider = 65kg
- 12) Speed(v) = 30km

tan⁻¹

1) Power calculation:-

Air drag , Pw =
$$\frac{Cd \times \rho \times A}{2} * (Vw + Vg)^2 * Vg$$

=
$$\frac{1 \times 1.225 \times 0.5}{2} * (1.94 + 6.94)^2 * 6.94$$

= 167.59 W

2) Rolling = P(roll) =
$$g * Cr * Mtot * Vg$$

=
$$9.18 * 0.0071 * 102 * 6.94$$

= 49.30 W

3) Climbing = gG = Road grade

=
$$Mtot * Vg * G$$

$$\begin{aligned} & \left(\frac{\text{m}}{\text{min}} \right)^{-1} \left(\frac{\Delta h / \Delta t}{100} \right) \\ & \left(\frac{\text{min}}{\text{m}} \right)^{-1} \left(\frac{10/50}{100} \right) \\ & = 13.81 \text{ W} \end{aligned}$$

$$\begin{aligned} 4) \text{ Total Power required} &= 167.59 + 49.30 + 13.81 \\ &= 230.7 \text{ W} \end{aligned}$$

∴ we select motor with power of 250 W

$$5) \text{ Battery Specifications: - Power} = \text{voltage} * \text{current}$$

$$250 = 24 * I$$

$$I = 10.41 \text{ Ah}$$

∴ we select 2 batteries of 12 V, 7.5 Ah. We connect these batteries in series to achieve a voltage as 24 V as required by motor.

6) Charging:-

1) Electric charging:- Power supplied to battery during charging by adaptor of specification 12 V, 3 A.

$$P = V * I$$

$$= 1 * 3$$

$$= 36 \text{ W}$$

Therefore time required to charge battery.

$$T = 180/36$$

$$= 5 \text{ hours}$$

$$\text{Battery (Ah)} = (127.5)2$$

$$= 180$$

2) Solar Panel:-

$$T = 180/25$$

$$= 7.2 \text{ hours}$$

ADVANTAGES

- Solar power is without contamination and makes no ozone depleting substances be radiated after establishment
- Reduced reliance on remote oil and petroleum products
- Virtually no upkeep as sun powered boards last more than 30 years
- Use batteries to store power
- The more prominent effectiveness, due to the immediate engine supply.
- Very helpful for driving rapidly and keeping away from traffic.

COMPARISON PARAMETER

Table 1

Parameter	Solar E- Bicycle	Moped
Max. Speed limit (Km/hr)	25-30	55-60
Initial Cost	14000-15000	50000+
Fuel use per 100 Km	Nil	2L+
Type of energy use	Solar	Petrol

CONCLUSION

Solar based helped bike is alteration of existing bike and driven by solar oriented vitality it can worked during the time liberated from cost when contrasted with other method of transmission. It is ecofriendly and contamination free as it doesn't have any emanations. Besides it is quiet and can be revived with the AC connector in the event of crisis and terrible climate. It is more financial for the basic man than the utilization of some other method of transportation.

REFERENCES

- [1]. An Overview of Existing Experiences with Solar-Powered E-Bike, Georgia Apostolou, Angèle Reinders and Karst Geurs. © 2018 by the authors. Submitted for possible open access publication under the terms and conditions of the Creative Commons Attribution (CC BY) license.
- [2]. Design and Implementation of Electric Assisted Bicycle with Self Recharging Mechanism, Vivek V Kumar, Karthik A, Ajmal Roshan, Akhil J Kumar. International Journal of Innovative Research in Science, Engineering and Technology, An ISO 3297: 2007 Certified Organization.
- [3]. Solar- Powered- E-Bike, Mayur Parmar, Rushi Trivedi, Santosh Nair, Vikit Vora. Imperial Journal of Interdisciplinary Research (IJIR) Vol-2, Issue-5, 2016 ISSN: 2454-1362
- [4]. Solar Powered Bike Sharing System with Electric Bikes: Department of Energy and Environment Division of Environmental, CHALMERS UNIVERSITY OF TECHNOLOGY Göteborg, Sweden 2014 Report no. 2014.