



Design and Fabrication of Multipurpose Agriculture Machine

Dr. M.S. Baseshankar¹, Amit Dhongale², Harshal Kukade³, Mangesh Wadaskar⁴

¹Professor, Dept. of Mechanical Engineering, SCET, Nagpur, Maharashtra, India

^{2,3,4}Students, Dept. of Mechanical Engineering, SCET, Nagpur Maharashtra, India

ABSTRACT

India is an agriculture based country in which, 70% of people depends on the outcome of farming. But if we observe that with increase in population the farm gets distributed among the family and because of this, farmer in India held averagely only two-acre farm. Also economically, farmers are very poor due to which they are unable to purchase tractors and other costly equipment's hence they use traditional method of farming. Basically, many farmers in India also use bullocks, horses and he-buffalo for farming operation. This will not satisfy need of energy requirement of the farming as compared to other countries in the world. So we are thinking that human and animal efforts can be replaced by some advance mechanization which will be suitable for small-scale farmer from economical and effort point of view. So we are developing this equipment which will satisfy all this need and to solve labour problem. In this machine we used two 12v motor for rotation of sprocket and chain arrangement assembly for lifting the cutting crop (Soybeans, Bengal gram, Green gram,) and move to in collecting tank for carrying to harvesting yard place. By using this machine human effort can replace by mechanism.

Key words: Agriculture Machine, Design, Fabrication

INTRODUCTION

We have pleasure in introducing our new project "design and fabrication of multipurpose agriculture machine", Agriculture is the dominant economic activity in over 6, 00,000 villages of India, populated by 742 million people. In the last six decades, great strides have been made in agriculture sciences. Locations specific technologies have been evolved which can help us to reach the potential of both resource-rich and resource-poor regions. Soybeans are one of the most popularly grown legumes, native to the East Asia and now grown almost everywhere. They are used, as oilseeds as they are made up of around 18% oil. Bengal Gram is an important pulse crop in India. its Botanical Name is Cicerarietinum L. It is one of the most important Rabi crops in India. We grew it in winter. Green gram (PharsalusaureusRoxby) is important pulse crops. The grains (whole or split) are used as a pulse or made into flour, and into straw and husk as fodder for cattle. Black gram originated in South Asia, where it has been in cultivation from ancient times and is one of the most highly prized pulses of India. It is very widely used in Indian cuisine. In India the black gram is one of the important pulses grown in both kharif and Rabi seasons.

LITERATURE REVIEW

1. Patil Nikhil (5 may 2018): In this research paper author gives statement, in the agricultural field faces some problem such as how to minimize the losses and how to increase productivity and how to minimize cost. For this they are used mechanical hybrid device. This device is transfer motion for using this making multipurpose agriculture machine.
2. Pro. S. N. Waghmare (2016): In this research paper author has mentioned importance of mechanization in agricultural by giving example. The conclusion from the paper was need of multifunctional single axel vehicle for pre and past harvesting. We have taken this as base for our research and further production of our multifunctional agricultural vehicle.
3. Dhatchanamoorthy. (2018): This is a vehicle which used for multiple purposes of agricultural field such as ploughing, seed sowing, levelling operation, water spraying operation, pesticide spraying operation, harvester. This vehicle runs on petrol as a fuel, engine type is 4 stroke single cylinder. It's a vehicle in which operator (farmer) can easily sit in it and operate it as automobile.
4. V.K. Tewari, A. Ashok Kumar, Satya Prakash Kumar, Brajesh Nare [2012]: In this research papers author have done case study on farm mechanization in west Bengal as being part of India it gives clear status about availability and progress in India. This ensured us to take right steps compared to current steps.

BASIC CONCEPT DESIGN

Concept to design a project for small scale farmer. And in one machine multi function can be performed with cheap cost as compared to other agriculture machine, For this concept not essential to skilled person. Mechanism of machine should be very simple.

DESIGN AND SPECIFICATION

Multipurpose agriculture machine consists of following component.

1. Chassis frame –MS pipe-2×2.5 ft.
2. DC motor 12v, 100rpm
3. Chain (length-3m) and Sprocket (dia-100)
4. Chargeable battery 12v
5. Hub wheel
6. Bearing (ball, no. 6204)
7. Basket light weight (mesh material)
8. Shaft (alloy steel)
9. Straws or spokes

1. Chassis Frame



Fig. 1 Frame

A consists of an internal framework that supports a man-made object in its construction and use. The chassis is considered to be one of the significant structures of an automobile. It is the frame which holds both the body of machine and the power. Various mechanical parts like, hub wheel, DC motor 12v, chain and sprocket, bearing, chargeable battery are bolted onto the chassis.

Specification: Length =762mm, Width =609.6mm Thickness =25.4mm

2. DC Motor

DC motor is mounted on body which is connected to sprocket for power transmission purpose. There are two motor are mounted on body which will run by chargeable battery. Dc motor used to transmit direct current electrical energy into mechanical energy.



Fig. 2 DC motor

Specification and calculation:

voltage=12v, current=8.333, high speed motor, power(P)= $v \times i = 12 \times 8.333 = 100$ Calculation: $P = 2\pi N T / 60$, Where,
P=power=100 watt, N=speed=100rpm, T=Torque=? $100 = 2\pi \times 100 \times T / 60$ $T = 6000 / 628.318$ $T = 9.54$ Nm

3. Chain and Sprocket



Fig. 3 Chain and Sprocket

Sprocket is connected to shaft for rotation and industrial chain is mounted on it to transmit power. The dc motor is connected to the driver sprocket. Power will transmit from driver sprocket to driven sprocket through industrial chain.

Specification: length of Chain =3000mm Sprocket:

Diameter =100mm

Inner diameter =25mm

Pitch =12mm

teeth =24

4. Chargeable Battery



Fig. 4 Chargeable battery

12v Battery is rechargeable battery mounted on body for power supply to getting better torque. Battery power supply to dc motor, motor will run on battery.

5. Hub Wheel



Fig. 5 Hub Wheel

The wheels are mounted on chassis frame with the help of axle. There are four wheel provided on it, two are bigger in size are mounted on rear side of frame and another two small wheel are in front of frame. Bearing is provided in wheel for reducing man effort to pushing machine.

Specification: Wheel Diameter= 355.6mm Bore diameter =47mm

6. Bearing



Fig. 6 Bearing

Bearing is installed in wheel for reducing man effort and getting smoothness to machine.

Specification: Bearing no.6204 Dimension =20mm×47mm×14mm inner diameter =20mm outer diameter =47mm

7. Basket or Collecting Tank

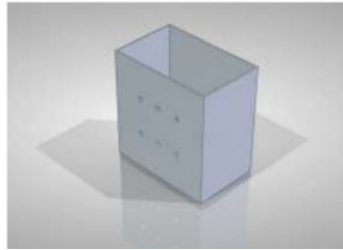

Fig. 7 Basket or Collecting Tank

Basket is use to collect cutting crops, cutting crops coming from ground level with the help of mechanical arrangement. Cutting crop from this basket will carry to harvesting yard.

WORKING OF MACHINE:

Main objective of this machine is to collect cutting crop from ground level and to carry to harvesting yard.

When the machine will operate by farmer start the motor to starting conveyor and this conveyor carry the cutting crops from ground level and this crop carry towards the basket or collecting tank. The cutting crops soyabean, bengalgram, green gram from collecting tank is then carry forward for harvesting yard with the help of collecting tank arrangement.

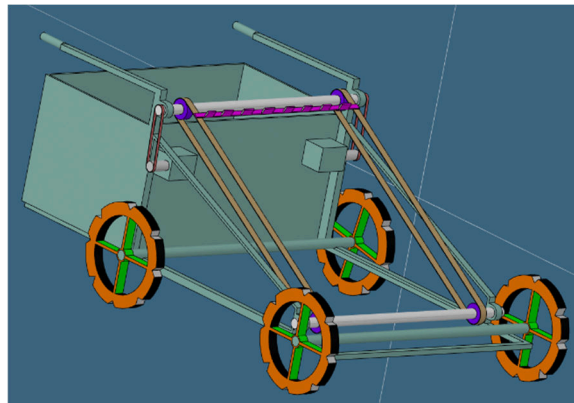

Fig. 8

MATERIAL USED

- 1) Chassis -MS pipe -2*2.5 ft.
- 2) DC motor 12v 100rpm
- 3) Industrial chain and sprocket
- 4) Chargeable battery 12v
- 5) Hub wheel 4
- 6) Bearing
- 7) Light weight basket or collecting tank
- 8) Straws OR spoke.

CONCLUSION

After the manufacturing and trial on the “Multipurpose Agricultural machine conclusion which made are as follows: Based on the overall performance of the machine we can definitely say that the project will satisfy the need of small scale farmer, because they are not able to purchase costly agricultural equipment. The machine required less man power and less time compared to traditional methods, so if we manufacture it on a large scale its cost gets significantly reduce and we hope this will satisfy the partial thrust of Indian agriculture. So in this way we solve the labour problem that is the need of today’s farming in India.

REFERENCE

- [1]. Agricultural Engineering (Through Worked Examples). 1971. Radhey Lal, A.C. Data.SarojPrakash 646, Katra, Allahabad-2.
- [2]. An Introduction to Agricultural Engineering.1982. Roth F.R, Crow G.W.A, Mahoney. AVI Publications Company, INC, Westport, Connecticut, USA.
- [3]. Design of Agricultural Tractor (Principles and Problems). 2010. D.N. Sharma, S. Mukesh. Jain Brothers, New Delhi-5.
- [4]. Mechanization in Fodder Production.2016. CS Sahay, PK Pathak, SK Singh. Indian Grassland and Fodder Research Institute, Jhansi-284003.
- [5]. Power Hydraulics. Michael J. Pinches, John G. Ashby. Prentice Hall, New York.
- [6]. Principles of Agricultural Engineering (Vol-1).1966. A.M. Michael, T.P. Ojha. Jain Brothers, New Delhi-5.
- [7]. Principles of Farm Machinery. 1987. R.A. Kepner, Roy Bainer, E.L. Barger. CBS Publishers & Distributors, New Delhi- 032. 1993.
- [8]. Chain idler sprocket image <https://www.mdsofmi.com/product/idler-sprocket-35bb18x12/>
- [9]. Solid rubber wheel image <https://www.amazon.in/NTN-Bearing-1207-Self-Aligning-Clearance/dp/B003B2YBEA>
- [10]. Radial ball bearing image <https://www.amazon.in/NTN-Bearing-1207-Self-Aligning-Clearance/dp/B003B2YBEA>
- [11]. Industrial conveyor chain <https://www.indiamart.com/proddetail/industrial-conveyor-chain-22284020612.html>