



Electricity Generation from Municipal Solid Waste (MSW)

Martin Karweru

Technical University of Mombasa , Kenya

ABSTRACT

With the world's energy demand increasing by the day, carbon dioxide emission rate also increases due to the dependency on fossil fuels for energy production. Several attempts have been made to reduce the dependence fossil fuels but to date coal is still a major energy resource used worldwide. The main focus of this paper is to investigate aspects with regard to the generation of energy by the use of biogas in terms of the economic, technological and environmental factors associated with the generation process.

Key words: Municipal Solid Waste, Anaerobic digestion, Biomass, micro turbine, Fuel, HOMER

1. INTRODUCTION

With industrialization and economic growth on a steep rise, more power is needed to sustain the world's ever increasing demand. There have been various blackouts and outages as a result of massive unpredictable demands of the world's energy usage that outgrew the supply. With increasing demand, the power and energy sector across the world is challenged to increase its supply. However increasing generation resulted in the heavy dependence on fossil fuels, and as a result energy generation becomes a major contributor to environmental pollution and global warming. Also, with increased usage, fossil fuels are likely to be depleted in future which will gradually lead to their price rising in the global market. These can be avoided or the rate slowed down, if properly backed up by alternate sources of sustainable energy. Global warming has also been reported to be on the increase. Global warming is mainly caused as a result of greenhouse gas emission into the atmosphere. Greenhouse gases include methane (CH₄), carbon dioxide (CO₂), nitrous oxides and ozone. Methane is reported to be 21 times more harmful than carbon dioxide. According to the renewable energy directive [1, 3], by 2020 every EU member has to have 20% of their energy generation from renewable sources which include biogas and bio fuels and 10% of the member states transport fuels must also come from renewable energy by 2020. It also requests that after every two year period, every member has to show how they have increased their renewable energy production [3]. In this paper the authors reports the electricity generation from the MSW in South Africa. Homer software was used for modeling the four cases investigated i.e. micro turbine stand alone, diesel engines, combination of diesel engines and biogas and the grid connected micro turbine system.

2. MUNICIPAL SOLID WASTE (MSW) AS A SOURCE OF BIOGAS

Municipal solid waste is a source of biogas since it contains carbohydrates, proteins, fats, cellulose and hemicellulose. Municipal solid waste (MSW) can be any organic and inorganic matter which includes papers, food remains, plastics, wood, dead plants and metals to mention a few. The constituent of biogas are methane (55-65%), carbon dioxide (40-50%), and traces of hydrogen sulphide and water.

MSW is readily available and its quantity and quality depends on the following: Geographic area, Population density of people, Climate conditions, Financial status whereby rich families produce bio waste which are poor in structure including leftovers, spoiled food etc. while poor families produce wastes which are fairly rich in structure and well suitable for anaerobic digestion and waste management policies.

A.1) Anaerobic digestion of MSW

Anaerobic reaction involves an oxygen free digestion of organic matter and converting it into methane gas and liquid effluent. Fig 1 depicts the process of the anaerobic reaction.

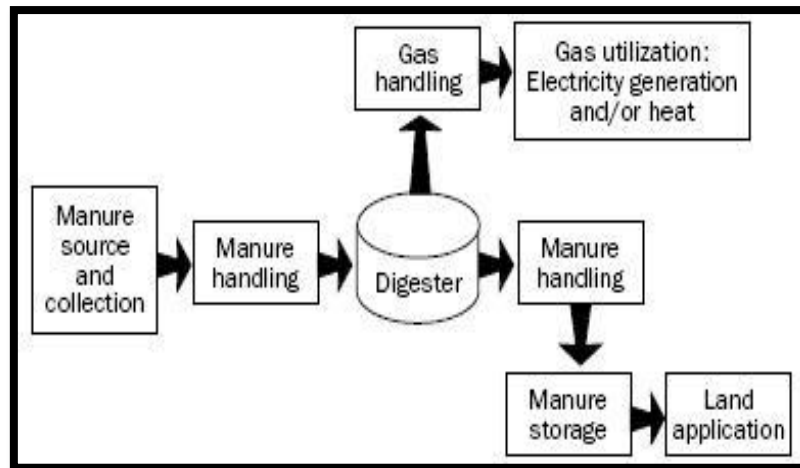

Fig. 1 Basic diagram of an anaerobic reaction [4]

The steps in biogas formation are:

Hydrolysis (acid-forming bacterial)

Undissolved compounds such as proteins, carbohydrates, and fats are converted into simple sugars, fatty acids, amino acids and peptides which are water-soluble by exoenzymes (hydrolase) and anaerobic bacteria.

Acidogenesis

Acidogens which are acid-forming bacteria are used to convert the by-product of hydrolysis into simple organic acids, alcohols, carbon dioxide and hydrogen.

Acetogenesis (Fermentation)

This step produces acetate, carbon dioxide and hydrogen. Acetogenic bacteria are known to be hydrogen producers. The presence of hydrogen prevents oxidation from occurring during acetogenesis. Hydrogen concentration can also be used as a testing of the digester [2, 5].

Methanogenesis

Methanogens are used to produce biogas (methane) from acetic acid or hydrogen and carbon dioxide. This stage is the slowest reaction during the anaerobic digestion process. The equations of methanogenesis process are shown below.

PARAMETERS THAT AFFECT ANAEROBIC DIGESTION

The efficiency of anaerobic digestion depends on certain parameters. These parameters affect the gas production as well as the rate of digestion and should be monitored and controlled to maintain them in acceptable ranges. Failure to keep these parameters in acceptable ranges results in slowing down of the digestion process and may lead to possible digester failure. These parameters include PH, temperature, ammonia concentration, retention time, carbon: nitrogen ratio, loading rate, toxicity and inhibitory substances, light [2-4].

3. MODELING AND ANALYSIS OF BIOGAS PRODUCTION FROM MSW

The model of the system was done on Homer. Homer is commonly used to evaluate different renewable power systems, either in off-grid or grid connected mode. HOMER requires various inputs, which it then uses to evaluate the possible system configurations. These inputs include component costs and resource availability. HOMER then uses the different component combinations to produce feasible configurations sorted by the net present cost. HOMER models biomass power systems using two ways. One way is that HOMER allows the user to define a fuel for the generator with properties which are the same as for the biomass feedstock. Next the user has to specify the fuel consumption of the generator which will show the biomass feedstock consumed against the electricity produced by the generator as a result of the specified biomass feedstock. The second way is to make use of the biomass resource. The user is prompted to input the available feedstock for the year. The biomass resource is defined in terms of the price, carbon content, gasification ratio as well as the energy content of the fuel. In this project, the second way is used, necessitated by the availability of the data for the biomass resource for Cape Town. The project life time chosen is 30 years. The average energy usage in South Africa shows that the geyser uses 40% of the total energy in the household consumption and the space heating contributes 16% of the total energy. This amounts to 56% which represents the thermal energy and the remaining 44% is for the electrical energy [8-9].

4. HOMER INPUTS

B.1) Primary Load (Electric) data

An electric load can be defined as an appliance that consumes electric energy. Household electric loads comprise of a refrigerator, stove, microwaves, water kettle, lighting etc. The load profile Fig 2 was adapted from [9].

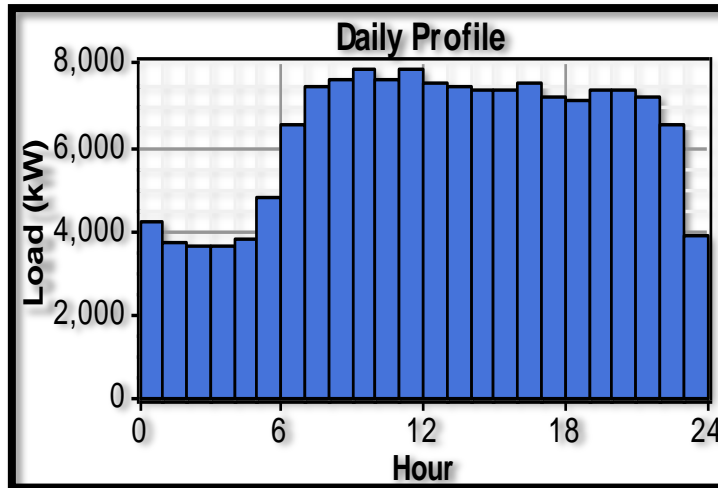

Fig. 2 Electric daily profile data for Cape Town households in winter [9]

B.2) Thermal Load data

A thermal load shown on Fig 3 can be defined as any appliance that used thermal (heat) energy. Thermal loads comprise of geysers and the heaters which are used mostly in winter.

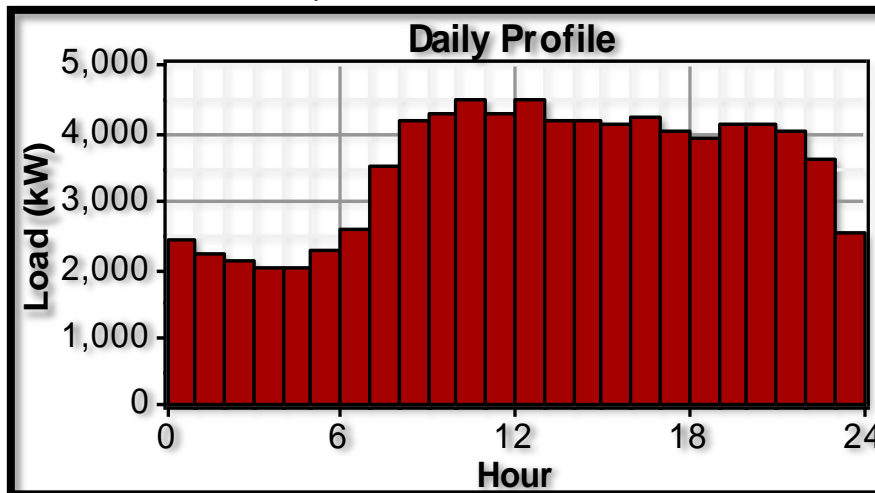

Fig. Error! No text of specified style in document. Thermal load daily profile for Cape Town households in winter [9]

B.3) Biomass resource data

This project uses Municipal Solid Waste (MSW) as a biomass resource. Thus for Cape Town CHP potential analysis, the biomass resource quantity was required. The data used in Table 1 was imported from reference [32] from Cape Town landfill sites.

Table -1 Amount of Waste per Month Given in Tons/Day [9]

Jan	Feb.	March	April	May	June	July	Aug	Sep	Oct	Nov	Dec
4,430	3,740	3,950	4,200	4,200	3,740	3,710	3,500	3,790	3,800	3,860	4,260

B.4) Diesel

Diesel prices have been fluctuating over the years. As a result one price value will not give a real indication of how diesel prices affect the system outputs. A price range of between \$0.9/L and \$1.5/L will be used to evaluate the diesel power system. This price range was chosen at the rate of 7 rands (R) per US dollar (\$) which corresponds to R6.3/L and

R10.5/L respectively. A large range was chosen to showcase how the variation in diesel prices affects the system outputs, specifically the net present cost.

B.5) Natural gas

Natural gas as used in this project is used to run the boiler. The boiler is used to supply thermal energy for the thermal load in case the micro turbine is not sufficient enough to supply the thermal energy demand. For the purpose of this project, the price used for natural gas is \$0.8/m³ [6].

B.6) Micro turbine

A capital cost of \$900/kW was chosen on the basis that it falls within the nominal cost range of a micro turbine. Replacement cost of a micro turbine was chosen to be 12% of the capital cost which indicates the cost necessary to replace the micro turbine. The O&M costs were estimated as follows: variable cost of \$0.00500/kWh and the fixed cost of as \$50/kWh yearly.

The overall O&M cost for a 1000kW micro turbine was calculated as shown in equation (1):

$$\text{Variable O\&M} + \text{Fixed O\&M} = 0.00500 * 1000 + \frac{50}{365 * 24} * 1000 \quad (1)$$

$$= \$10.77/\text{kWh}$$

The value of O&M used was rounded up to \$11.

The micro turbine sizes that will be simulated in HOMER range from 1000kW to 3000kW. The above mentioned costs are displayed in a Table 2.

Table -2 Micro Turbine Costs

Size (kW)	Capital (\$)	Replacement (\$)	O&M (\$/hr.)
1000.000	900000	748800	11.000
3000.000	2496000	2246400	33.000

For heat production, boilers are used to provide thermal energy to the thermal load in the case when the supply is not sufficient to meet the thermal demand. The boiler in HOMER is modeled to provide as much heat supply as needed by the thermal load [8]. The efficiency of the boiler was chosen to be 85% and the fuel used by the boiler is natural gas[8].

B.7) Converter

The converter is used to convert the voltage from AC to DC to be stored by the battery as well as from DC to AC to be used by the load from the battery storage. The efficiency of the converter used is 90% and the life time for the converter was chosen to be 15 years. The converter used for this study ranges from 2000kW to 5000kW as shown in table 3.

Table -3 Converter Costs

Size (kW)	Capital (\$)	Replacement (\$)	O&M (\$/yr.)
2000.000	50000	45000	3200
5000.000	125000	112500	8000

B.8) Battery

The battery is used to store excess energy in case when the electrical supply is more than the demand. This energy is then used during times when the supply may not be sufficient to meet the electric demand. The battery chosen for HOMER simulation is the First National Battery abbreviated as CCA SAE 700. This battery was used in this model due to its common use in South Africa.

The battery is rated at 12V and has a nominal capacity of 102 Ah. Table 4 shows the first national battery specifications and properties as used in HOMER

Table -4 Battery Costs

Quantity	Capital (\$)	Replacement (\$)	O&M (\$/yr.)
10	1200	800	50

B.9) Diesel Engine

Diesel engines uses diesel as a fuel for energy production. A review of the difference between micro turbine and diesel engines has been presented in chapter 2. For the purposes of comparisons between the micro turbine and diesel engine, the same sizes as for the micro turbine is used for the diesel engines. Diesel Engines as used in HOMER are given in the Table 5 according to reference [8].

Table -5 Diesel Engine Costs

Size (kW)	Capital (\$)	Replacement (\$)	O&M (\$/hr.)
1000.000	550000	484000	10
3000.000	1650000	1452000	30

5. RESULT AND ANALYSIS

The simulation was done for four different cases namely:

Case 1: CHP Stand Alone system using micro turbines

Case 2: CHP Stand Alone system using Diesel Engines

Case 3: CHP Stand Alone system using a combination of micro turbines and Diesel Engines

Case 4: CHP Grid connected system using micro turbines

Simulation of CHP Stand Alone system using micro turbines

The application of this case was mostly for rural areas which are not connected to the grid for reasons such as, they are very far from the network thus it will be expensive to connect them to the grid. The energy generated will be used to supply both the electrical load and the thermal load. Excess electric energy will be stored in the battery and used during peak times in case the electric energy generated is not enough to supply the demand. A boiler is also included in the system to generate thermal energy for the thermal load when the micro turbine is not enough to supply the thermal demand. The schematic diagram is shown on figure 4.

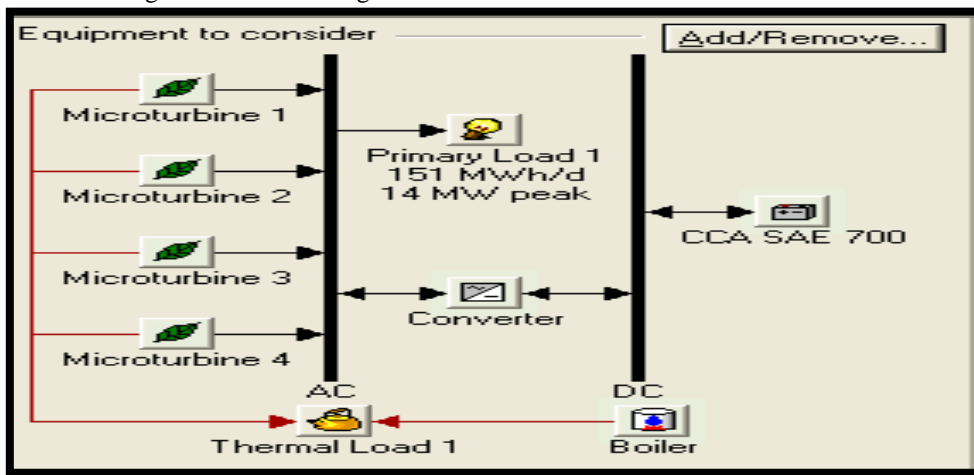

Fig. 4 Case 1 HOMER schematic model

Table -6 All Cases Components Sizes to Consider

Option	Microturbine size in kW	Converter Size in kW	Battery Size in strings
1	0	0	0
2	1000	2000	1
3	3000	5000	

HOMER then finds possible size combinations which will be able to meet the demand. The different combinations are displayed from the best combination to the last combination in terms of the parameters shown in Figure 5. The best size found was 3000kW for the micro turbines and 2000kW for the converter.

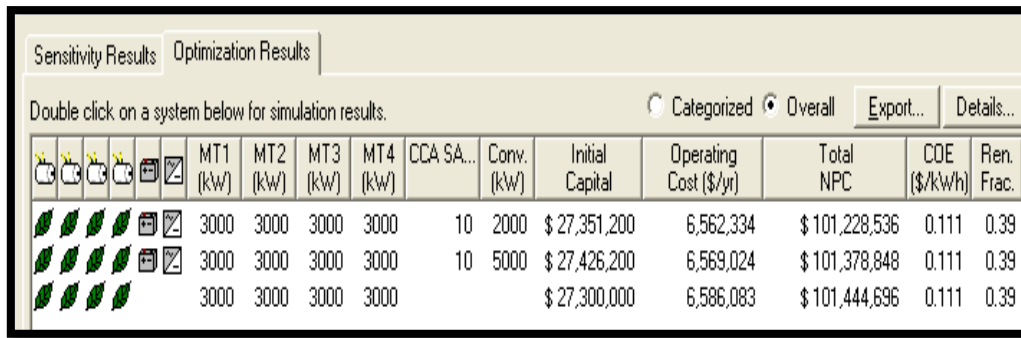

Fig. 5 Optimization results for case 1 System

Table -7 Case 1 Components Cost Summary

Component	Capital (\$)	Replacement (\$)	O&M (\$)	Fuel (\$)	Salvage (\$)	Total (\$)
Microturbine 1	2,700,000	14,249,156	3,254,027	468,580	-107,602	20,564,168
Microturbine 2	2,700,000	13,525,938	3,111,740	2,686	-55,363	19,285,004
Microturbine 3	2,700,000	8,224,109	1,980,131	1,223	-75,902	12,829,558
Microturbine 4	2,700,000	2,172,495	680,600	304	-75,009	5,478,390
Boiler	0	0	0	24,786,620	0	24,786,620
Battery	1,200	4,439	563	0	-398	5,804
Converter	50,000	14,186	36,025	0	0	100,211
Other	16,500,000	0	1,678,786	0	0	18,178,788
System Total	27,351,200	38,190,316	10,741,872	25,259,408	-314,274	101,228,520

Micro turbine 1 appears to have higher total costs because it was in operation for a longer period as compared to all the other components in the system as indicated in Table 8

The overall system cost is found to be \$ 101,228,520. This indicates the amount spent in buying the equipments (capita costs), replacement of the equipments, operation and maintenance (O&M), fuel and salvage. This is how much the entire project cost at the end of its life time.

Table -8 Case 1 Component Simulation Results

Component	Electrical Production (kWh/yr.)	Thermal Production (kWh/yr.)	Fuel Consumption (kWh/yr.)	Hours of operation (Hr/yr.)	Fuel consumption (m3/yr.)	Bio. Feedstock consumption (t/yr.)
Microturbine 1	25,453,762	3,287,252	-	8,759	-	8,753,802
Microturbine 2	19,026,888	2,491,566	-	8,376	-	47,722
Microturbine 3	8,442,706	1,135,695	-	5,330	-	21,728
Microturbine 4	2,025,967	282,849	-	1,832	-	5,404
Boiler	-	23,100,990	-	8,759	2,752,166	-
AC primary load	-	-	54,947,468	-	-	-
Thermal load	-	-	30,298,662	-	-	-
Battery	-	-	-	-	-	-
Converter	-	-	-	1825	-	-
System Total	54,949,320	30,298,352	-	-	-	8 828 656

Microturbine 1 is found to operate for 8,759 Hours per year, which is higher than all the other micro turbines which indicate why in Table 8 it is found to have higher overall costs than the other components in the system model. The total

thermal production is seen to be lower than the total electricity production because HOMER ensures that the electrical load demands are met first before it can supply the thermal load.

Case 1 cash flow

As it can be seen from Figure 6, at the beginning of the project, the only cost is the capital cost for all the equipment which amounts to \$ 26 000 000 as shown in red. After the first year, the cash flow is only influenced by the replacement costs; O&M costs fuel and salvage. The replacement costs appear each year because batteries need to be replaced about 3 or more times each year. The cash flow is fluctuating below \$ 7 500 000 until the fourth month and shoots up to \$ 10 000 000 because by that time some equipments need to be replaced. The cash flow remained fluctuating below \$ 10 000 000 except on the 16th and the 26th year when some equipments will require replacement.

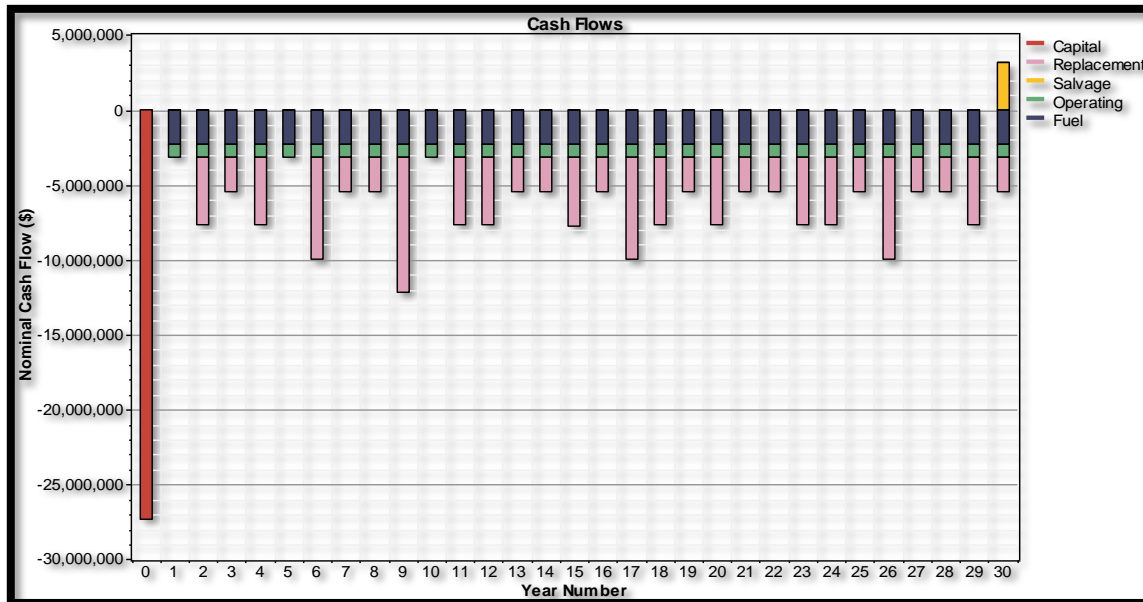

Fig. 6 Case 1 Cash flow of the system

Case 2: Simulation of a CHP stand-alone system using Diesel engines

The application of this case is mostly for areas (rural areas and small farms) which are not connected to the grid. Diesel engines are then used for energy generation. This case analyses the effect of diesel price fluctuations on the production of energy. The prices used ranges from between \$0.9/L and \$1.5/L. Diesel engine uses diesel to produce energy to supply the thermal and electric loads while the excess electric power will be stored in the battery. The stored electrical power will then be used by the electric load in the case when the electric demand is higher than the energy produced.

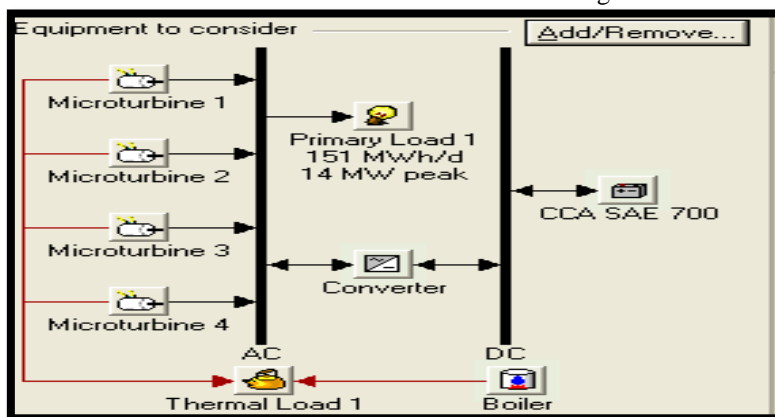

Fig. 7 Case 2 Homer Schematic

In this case HOMER only considered 3000kW micro turbine amongst the different sizes to consider given in Table 9. This is because the use of 1000kW micro turbines will not sufficiently supply enough energy to meet the demand. The best case for this system appears in the first row which has a Cost of Energy of \$1.666/kWh and the renewable fraction is zero due to the fact that diesel is a non-renewable resource.

Table -9 Case 2 Component's Costs Summary

Component	Capital (\$)	Replacement (\$)	O&M (\$)	Fuel (\$)	Salvage (\$)	Total (\$)
Microturbine 1	1,650,000	9,210,192	3,254,027	446,860,608	-69,551	460,905,344
Microturbine 2	1,650,000	8,742,727	3,111,740	338,460,480	-35,785	351,929,152
Microturbine 3	1,650,000	5,315,797	1,980,131	154,104,896	-49,060	163,001,760
Microturbine 4	1,650,000	1,404,230	680,600	38,324,704	-48,483	42,011,064
Boiler	0	0	0	27,134,206	0	27,134,206
Battery	1,200	4,439	563	0	-398	5,804
Converter	50,000	14,186	36,025	0	0	100,211
Other	16,500,000	0	1,678,786	0	0	18,178,788
System Total	23,151,200	24,691,574	10,741,872	1,004,884,864	-203,277	1,063,266,432

Case 2 Component simulation results

This section shows the results of the different components in the system corresponding to the overall best combination for this case in terms of the energy produced, energy consumed, hours of operation, fuel consumed and biomass consumed.

Table -10 Case 2 Components Simulation Results

Component	Electrical Production (kWh/yr.)	Thermal Production (kWh/yr.)	Consumption (kWh/yr.)	Hours of operation (Hr/yr.)	Fuel consumption (m3/yr.)	Bio. Feedstock consumption (t/yr.)
Microturbine 1	25,453,774	2,287,823	-	8,759	44,103,892	-
Microturbine 2	19,026,868	1,734,240	-	8,376	33,405,098	-
Microturbine 3	8,442,742	790,820	-	5,330	15,209,720	-
Microturbine 4	2,025,976	197,089	-	1,832	3,782,541	-
Boiler	-	25,288,932	-	8,759	3,012,829	-
AC primary load	-	-	54,947,468	-	-	-
Thermal load	-	-	30,298,662	-	-	-
Battery	-	-	-	-	-	-
Converter	-	-	-	36	-	-
Total	54,949,360	30,298,904	-	-	99 514 081	0

The simulations obtained for case 2 are shown in Table 10. Diesel engines make use of diesel therefore the biomass feedstock consumption is zero while the total fuel consumption is 99 514 081 m³/year. The total electricity production is 54,949,360 kWh/yr, whereas the thermal production is 30,298,904 kWh/yr.

Case 2 Cash flow results

The cash flow definition as given is the flow of money during the project lifetime. Negative cash flow indicates expenditure while positive cash flow indicates income of the system during the duration of the project life time. Due to diesel price fluctuations, the price of diesel is varied between \$0.9/L to \$1.5/L. From Figure 8 it can be seen that the capital cost is \$ 22 000 000 which is very small compared to the fuel cost as indicated in blue. This indicates that a diesel engine system cash flow is highly influenced by the fuel (diesel) cost and little by the replacement costs or the operating costs of the system's components.

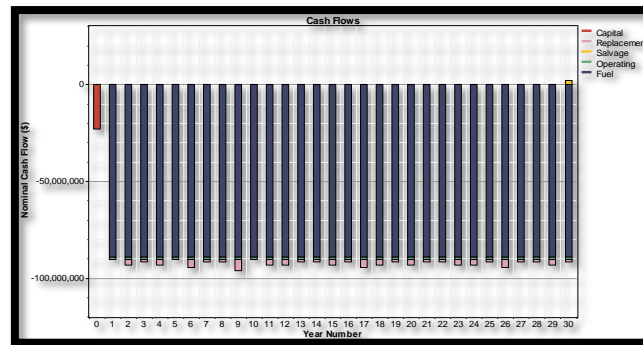

Fig. 8 Cash flow for Diesel Costing 0.9\$/l

CASE 3: Simulation of CHP grid connected system using micro turbines and Diesel Engines

This case is applicable in areas where there are less biomass resources which is not enough to supply the demand. Thus there is a need to combine the microturbines with the diesel engines to be able to satisfy the demand. The diesel price used for this case study is 0.9\$/L. This case combines the two previous cases, by making use of two microturbines and two diesel engines. These generators are then used to generate energy to supply the thermal load and the electric load. The model was as shown in Figure 9.

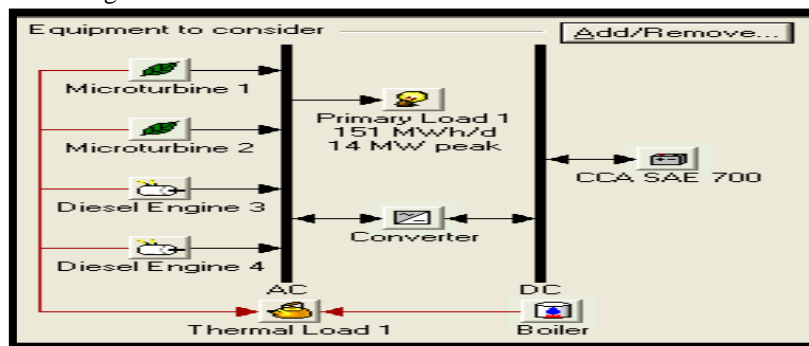

Fig. 1 Case 3 HOMER Model Schematics

The optimized results obtained from the homer simulation were as shown in figure 10.

Sensitivity Results		Optimization Results											
Double click on a system below for simulation results.													
<input type="radio"/> Categorized <input checked="" type="radio"/> Overall <input type="button" value="Export..."/> <input type="button" value="Details..."/>													
Icons	MT1 (kW)	MT2 (kW)	DE 3 (kW)	DE 4 (kW)	CCA SA...	Conv. (kW)	Initial Capital	Operating Cost (\$/yr)	Total NPC	CDE (\$/kWh)	Ren. Frac.		
	3000	3000	3000	3000	10	2000	\$ 25,251,200	23,374,784	\$ 288,399,456	0.414	0.25		
	3000	3000	3000	3000	10	5000	\$ 25,326,200	23,381,474	\$ 288,549,792	0.414	0.25		
	3000	3000	3000	3000			\$ 25,200,000	23,486,778	\$ 289,609,088	0.416	0.25		

Fig. 2 Case 3 Optimization results

Table -11 Case 3 Component Cost Summary

Component	Capital (\$)	Replacement (\$)	O&M (\$)	Fuel (\$)	Salvage (\$)	Total (\$)
Microturbine 1	2,700,000	14,249,156	3,254,027	468,778	-107,602	20,564,362
Microturbine 2	2,700,000	13,528,512	3,112,483	2,689	-54,471	19,289,208
Diesel Engine 3	1,650,000	5,321,583	1,982,731	153,826,624	-47,040	162,733,920
Diesel Engine 4	1,650,000	1,416,596	686,544	38,558,384	-43,866	42,267,652
Boiler	0	0	0	25,245,398	0	25,245,398
Battery	1,200	9,538	563	0	-692	10,609
Converter	50,000	14,186	36,025	0	0	100,211
Other	16,500,000	0	1,687,972	0	0	18,187,970
System total	25,251,200	34,539,576	10,760,348	218,101,872	-253,672	288,399,328

Simulation Component Results

The best case chosen by HOMER as indicated in the first row of Figure 10 shows that the four generators used were all rated at 3000kW. Table 12 shows the different energy productions, fuel and biomass consumptions of different generators as well as the thermal and electrical consumptions by the loads.

Table -12 Case 3 Simulation Results Per Component

Component	Electrical Production (kWh/yr.)	Thermal Production (kWh/yr.)	Consumption (kWh/yr.)	Hours of operation (Hr/yr.)	Fuel consumption (m3/yr.)	Bio. Feedstock consumption (t/yr.)
Microturbine 1	25,460,688	3,288,103	-	8,759	-	8,757,425
Microturbine 2	19,046,230	2,493,978	-	8,378	-	47,768
Diesel Engine 1	8,425,087	789,406	-	5,337	15,182,259	-
Diesel Engine 2	2,037,627	198,295	-	1,848	3,805,604	-
Boiler	-	23,528,572	-	8,759	2,803,106	-
AC primary load	-	-	54,946,872	-	-	-
Thermal load	-	-	30,298,662	-	-	-
Battery	-	-	-	-	-	-
Converter	-	-	-	7846	-	-
Total	54,969,636	30,298,352	-	-	-	8 805 193
Total Diesel used	-	-	-	-	18 987 863	-

Table 12 shows the simulation costs for case 3 indicated per component. The total biomass feedstock used for the two 3000kW microturbine totals to 8 805 193 tonnes/year while the diesel used for the two diesel engines is 18 987 863 m³/year. The total electric production was found to be 54,969,636 kWh/yr. while the total thermal production is 30,298,352 kWh/yr. Since HOMER chooses the best possible combinations, it can be seen from Table 12 that the two microturbines are used for longer period than the diesel engines in order to limit the use of operating diesel engines due to the high cost associated with buying diesel and the high amount of carbon dioxide it produces.

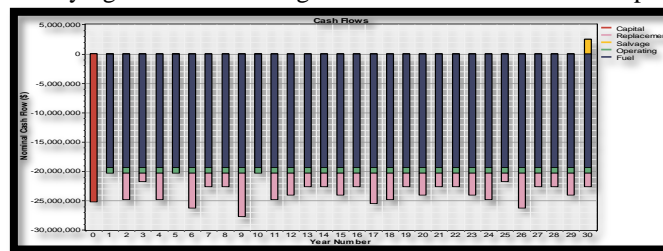

Fig. 3 Case 3 Nominal cash flow

The nominal cash flow is shown in Figure 11. At the beginning of the project, the capital cost is the only cost contributing to the cash flow. After the first year, the replacement cost, operating costs, fuel and salvage are the only costs influencing the cash flow.

Figure 11 shows that in the first year the negative cash flow amount found is \$25 100 00 whereas the maximum negative amount is \$27 000 000. The cash flow remained negative indicating an outflow of cash from the system for the entire duration of running the project which is 30 years. The cash flow is influenced greatly by the fuel cost as can be seen in blue.

Case 4: Simulation of CHP grid connected system using microturbines

This case is applicable in areas where the demand is low (the microturbine system has to sell power to the main grid) or where the demand is high compared to the system production capacity (the microturbine system has to import power from the grid). Various ranging grid prices are used to analyse the economic viability of a grid connected system. In this case the system can receive money when selling power to the grid and thus helping reduce the power generation deficit, especially during peak times when Eskom generation capacity is highly constrained. In these case four microturbines are used each rated at 3000kW to produce maximum energy. HOMER model for the grid connected system is shown in Figure 12.

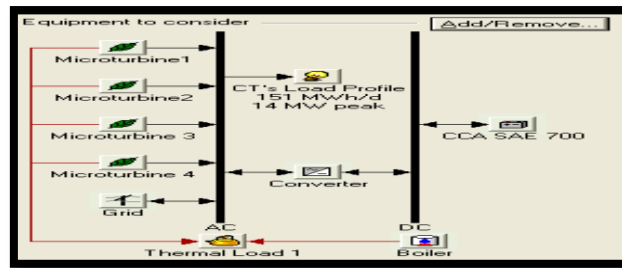

Fig. 4 Case 4 HOMER model schematic

Optimization results and the component costs

As mentioned in previous sections, the optimization results refer to the best combination of the different component sizes as implemented by HOMER. Table 11 shows the different grid prices considered in the optimization analysis.

Table -13 Case 4 Grid Prices

Rate	Power Price (\$/kWh)	Selling back rate (\$/kWh)	Demand rate (\$/kW/mo)
Peak	0.130	0.05	0.75
Off-peak	0.04, 0.05, 0.06	0.05	0.50

Table 11 contains different prices used to sell and to buy electricity from the grid. The values used correspond to three scenarios which were discussed in chapter 3. The best case is always indicated in the first row of the optimization result table shown in Figure 13 and Figure 14. In this case all the micro turbines used are rated at 3000kW.

System	MT1 (kW)	MT2 (kW)	MT3 (kW)	MT4 (kW)	CCA SA...	Conv. (kW)	Grid (kW)	Initial Capital	Operating Cost (\$/yr)	Total NPC	COE (\$/kWh)	Ren. Frac.
1	3000	3000	3000	3000	10	2000	1000	\$10,862,000	5,531,411	\$81,572,000	0.064	0.43
2	3000	3000	3000	3000	10	5000	1000	\$10,937,000	5,538,004	\$81,731,280	0.064	0.43

Fig. 13 Case 4 Optimization results corresponding to the off-peak price of \$0.04/Kwh

System	MT1 (kW)	MT2 (kW)	MT3 (kW)	MT4 (kW)	CCA SA...	Conv. (kW)	Grid (kW)	Initial Capital	Operating Cost (\$/yr)	Total NPC	COE (\$/kWh)	Ren. Frac.
1	3000	3000	3000	3000	10	2000	1000	\$10,862,000	5,536,618	\$81,638,552	0.064	0.43
2	3000	3000	3000	3000	10	5000	1000	\$10,937,000	5,543,211	\$81,797,832	0.064	0.43

Fig. 14 Case 4 Optimization results corresponding to the off-peak price of \$0.06/Kwh

Figure 13 and Figure 14 shows that the Cost of Energy is \$0.064 /kWh while the renewable fraction is 0.43. The difference between the Figure 13 and Figure 14 is only in the operating cost which are \$ 5 531 411 and \$5 5 36 618 respectively, and the total NPC which are \$81 572 000 and \$81 638 552 respectively which corresponds to the first row of each table. The natural gas and the biomass resource used are the same in both scenarios, 674,496 and 9,165,023 tonnes/year respectively.

Table -14 Case 4 Component Costs Corresponding To 0.06\$/Kwh Grid Price

Component	Capital (\$)	Replacement (\$)	O&M (\$)	Fuel (\$)	Salvage (\$)	Total (\$)
Microturbine1	2,700,000	16,112,670	3,694,993	552,128	-210,236	22,849,562
Microturbine2	2,700,000	13,735,149	3,182,866	3,408	-222,449	19,398,972
Microturbine 3	2,700,000	7,514,604	1,795,820	1,760	-473,685	11,538,499
Microturbine 4	2,700,000	867,846	387,681	301	-245,130	3,710,698
Grid	0	0	-3,342,886	0	0	-3,342,886
Boiler	0	0	0	27,351,242	0	27,351,242
Battery	12,000	14,872	639	0	-1,189	26,322
Converter	50,000	18,777	40,907	0	-3,495	106,189
System Total	10,862,000	38,263,928	5,760,019	27,908,838	-1,156,184	81,638,616

Table 14 indicates a summary of the components cost. It can be seen that the four microturbines have the same capital costs but microturbine 1 contributes more to the replacement costs and to the O&M costs which corresponds to \$16,112,670 and \$3,694,993 respectively and this is because it has more operating hours than the other microturbines. The total system cost is \$81,638,616 which includes all the costs of all the components while the fuel cost is \$27,908,838 for a period of 30 years. The total overall salvage of the system is given by -\$1,156,184.

Case 4 simulation results

Simulation results include the electrical and thermal energy produced by the microturbines and the grid. It also shows the energy consumed by the thermal load, electrical load as well as the grid when it buys electricity from the system. It also shows the fuel and the biomass resource consumed by the boiler and the microturbine respectively.

Table -15 Components Simulation Results Corresponding To 0.06\$/Kwh Grid Price

Component	Electrical Production (kWh/yr.)	Thermal Production (kWh/yr.)	Consumption (kWh/yr.)	Hours of operation (Hr/yr.)	Fuel consumption (m3/yr.)	Bio. Feedstock consumption (t/yr.)
Microturbine 1	26,249,282	3,384,815	-	8,759	-	9,079,478
Microturbine 2	21,520,108	2,781,939	-	7,545	-	53,314
Microturbine 3	11,059,822	1,436,889	-	4,257	-	27,529
Microturbine 4	1,861,227	245,589	-	919	-	4,702
Grid	367,068	-	6,061,281	-	-	-
Boiler	-	22,449,048	-	8,759	2,674,496	-
AC primary load	-	-	54,968,464	-	-	-
Thermal load	-	-	30,298,662	-	-	-
Battery	-	-	-	-	-	-
Converter	-	-	-	903	-	-
Total	61,057,508	30,298,276	-	-	-	9 165 023

The simulation results corresponding to a grid price of \$0.06/kWh are shown in Table 15. The total electricity production is found to be 61,057,508 kWh/yr while the thermal production is 30,298,276 kWh/yr. The grid consumes a total of 6,061,281 kWh/yr. The system has a total biomass feedstock consumption of 9 165 023 tonnes/ year. The converter was used for 903 hours of operation to convert from AC to DC and vice versa.

Case 4 Cash flow results

The cash flow indicates how the money is flowing in the project. The more negative the cash flow is, the more expenses the project has and the more positive the cash flow is, the more income the project is generating. The cash flow is made up of a summation of the capital costs, operating costs, salvage, fuel and replacement costs. Figure15 shows the cash flow of the system over the duration of the project life time.

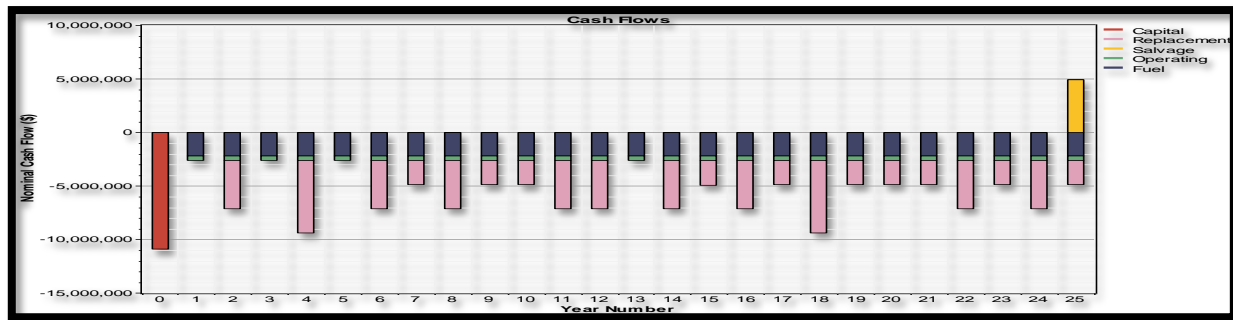

Fig. 15 Cash flow of 0.04\$/kWh selling price

Figure 15 shows that the lowest negative cash flow is \$2 500 000 recorded in year 1 while the maximum negative cash flow is \$11 000 000, recorded at the initiation of the project. This is as a result of the capital expenditure during the project start-up. It can be seen that the cash flow is fluctuating having a minimum of \$2 400 000 for the first, third, fifth and thirteenth year due to the fuel and operating costs and a maximum of \$9 400 000 for the fourth and the eighteenth year as a result of the replacement costs. Because this system is connected to the grid, it uses less fuel because the grid compensates it.

6. Emissions

Table 16 shows the different emissions for each case where case 1 is the micro turbine stand alone, case 2 is the diesel engine stand alone, case 3 is the micro turbine with diesel engines stand alone and case 4 is the micro turbine grid connected system. It can be seen that case 2 which corresponds to a system with four Diesel engines have a largest positive CO₂ emissions of 259,966.752 kg/year which means that every year case 2 system releases 259,966.752 kg of CO₂ per year. The rest of the cases release a negative carbon dioxide emission value which corresponds to the fact that the system is not releasing carbon dioxide into the air but it is rather reducing the carbon dioxide in the atmosphere if the same amount of energy was generated using coal. The more negative the emission, the more environmental friendly the case is. Both of the cases produces a positive sulphur dioxide which means that both cases emit sulphur dioxide into the atmosphere.

Table -16 Emissions For The Four Cases

Pollutant	Case 1	Case 2	Case 3	Case 4
Carbon dioxide	-475,573.216	259,966.752	-492,612.960	-425,620.832
Carbon monoxide	-172.389	627.258	-176.623	-49.171
Unburned hydrocarbons	-19.095	69.481	-19.564	-5.447
Particulate matter	-12.995	47.286	-13.315	-3.707
Sulphur dioxide	14.350	526.025	-1.657	115.027
Nitrogen oxides	-1,538.240	5,597.073	-1,583.648	-438.757

7. Conclusions

It has been deduced from tables (8,10,12,15) that the stand alone, diesel engine and the diesel+microturbine systems have approximately the same electricity production capacity of 55 000000 kWh/yr. However the Grid connected system has a large electricity production capacity of approximately 61 000 000 kWh/yr and this is because the system can sell electricity to the grid in the case of excess production. The amount of energy generated for the first three cases are only to supply the electrical loads, while in the grid connected system, the system is supplying the electrical loads and also supplementing the grid. This usually happens during grid peak times, when the grid can no longer sustain the electrical load and thus the system will have to sell energy to the grid. The diesel engine system cost 2.018 c/kWh which is higher than the rest of the three systems of which the grid connected system costs 0.064c/kWh which is the lowest. This was because of the high cost of diesel. A negative CO₂ emission means that the carbon dioxide is being removed from the atmosphere whereas a positive CO₂ emission means that the system is emitting CO₂ into the atmosphere. The diesel engine is the only system with positive CO₂ emissions. The Grid connected system has a much lower CO₂ emissions as compared to the stand alone system. R&D should be done to establish results of combination of diesel and biogas for standalone applications to be applied in the rural areas. The emitted heat can also be reused and applied for other hybrid renewable energy applications.

REFERENCES

- [1] Ernsting, "Biomass and Biofuel in the renewable energy directive", 2009.
- [2] Melissa-jade Williams and S P Chowdhury, "Electricity generation from municipal solid waste," University of Cape Town, Undergraduate Thesis 2010.
- [3] D Deublein and A Steinhauser, *Biogas from waste and renewable resources*, 2nd ed., Wiley-VCH Verlag GmbH & Co.kGaA, Ed.: Weinheim, 2011.
- [4] Arogo Ogejo Jactone, Extension Specialist, Biological Systems Engineering, Virginia Tech Zhiyou Wen, Extension Specialist, Biological Systems Engineering, et al., "Biological Technology ", Publication 442-881, (2011, August) [Online]. <http://pubs.ext.vt.edu/442/442-881/442-881.html>
- [5] Adele Boadzo and S Chowdhury, "Renewable energy energy generation using biogas," University of Cape Town, Undergraduate Thesis 2010.
- [6] A. Marchan, "Case study: Biogas and power generation from wastewater treatment," USAID, 1998.
- [7] H Winkler, "Renewable Energy Policy in South Africa: Policy options for renewable energy," *Energy Policy*, vol. 33, pp. 27-38, 2005.
- [8] Kgomotso M. Sekgoele and S P Chowdhury, "Technical and economic assessment of energy generation from landfill gas," University of Cape Town, Undergraduate Thesis 2010.
- [9] Kgomotso Mapula Sekgoele and S.P Chowdhury, "Technical and economic assessment of energy generation from landfill gas", University of Cape Town, Undergraduate Thesis, 2010